



OWNER INFORMATION PACKET

Building Number: _____ Unit Number: _____

Owner Name: _____ Date of Birth _____

Cell # _____ Office # _____

Home # _____ Email: _____

Owner Name: _____ Date of Birth _____

Cell # _____ Office # _____

Home # _____ Email: _____

Alternative Mailing Address: _____

EMERGENCY CONTACT:

Name: _____ Relationship: _____ Phone # _____

Name: _____ Relationship: _____ Phone # _____

Does Emergency Contacts have a key to your unit? _____

OTHER OCCUPANTS IN UNIT:

Name: _____ Relationship: _____

Name: _____ Relationship: _____

OTHER OCCUPANTS IN UNIT UNDER THE AGE OF 12:

Name: _____ Relationship: _____

Name: _____ Relationship: _____

Owner signature _____ Date _____

Owner Signature _____ Date _____

Management Signature _____ Date _____



PET INFORMATION

Please read section 17.3 of the Declaration regarding pet restrictions (attached). Please provide a picture of pet(s) when returning this packet to the management office.

Building # _____ Unit # _____

Do you have any pets? _____ How many? _____

DETAILED PET INFORMATION

Type of Pet: **(1)** _____

Pet's Name: _____ Breed _____ Color: _____ Weight _____ Age _____

Type of Pet: **(2)** _____

Pet's Name: _____ Breed _____ Color: _____ Weight _____ Age _____

ASSOCIATION PET RULES:

- PET MUST BE NO MORE THAN 35 LBS FOR DOGS AND 15 LBS. FOR CATS.
- ALL SERVICE AND EMOTIONAL SUPPORT ANIMALS MUST GO THROUGH AN APPLICATION PROCESS TO VERIFY LEGITIMACY.
- ONE PET PER BEDROOM. TWO PETS MAXIMUM.
- PET OWNERS ARE REQUIRED TO PICK UP ANY SOLID WASTE FROM THEIR PET WHEN WALKING OUTSIDE AND DISPOSED OF PROPERLY. THERE ARE DOGGIE STATIONS LOCATED THROUGH OUT THE PROPERTY.
- PETS MUST ALWAYS BE ATTENDED BY AN ADULT AND BE RESTRAINED WITH A LEASH NO MORE THAN 6 FEET IN LENGTH WHEN OUTSIDE ON COMMON GROUNDS.

OWNERS ACKNOWLEDGMENT

I AM AWARE OF THE VILLAS AT EMERALD DUNES CONDOMINIUM CONCEPTS RULES, REGULATIONS, AND RESTRICTIONS REGARDING PETS ON THE PROPERTY AND AGREE TO ABIDE BY THEM.

Name: _____ Building #: _____ Unit #: _____

Signature: _____ Date: _____

Name: _____ Building #: _____ Unit #: _____

Signature: _____ Date: _____



Installations

No radio station or short wave operations of any kind shall operate from any Unit, Limited Common Elements or Common Elements. Except to the extent permitted under applicable laws, no exterior satellite dish, or other transmitting or receiving apparatus, radio antenna, television or other antenna of any type shall be erected or maintained on the common elements, Limited Common Elements, or Units, without the prior written consent of the Association. Notwithstanding the forgoing, upon obtaining the prior written consent of the association, satellite dishes and other devices permitted under applicable law, may be installed within the units or within any Limited Common Elements appurtenant thereto, provided, however, that in no event shall any such device be installed in or on any other portion of the Condominium Property. To the extent permissible under applicable law, the Association may enact Rules and Regulations, requiring that any devices which may be permitted under applicable law are comparable in size and weight and appearance, are installed and maintained in a manner designed to protect the safety of the buildings and its occupants and satisfy any standards established by the association for architectural appearance purposes. In addition, the foregoing is subject to (and the Unit Owners agree to be bound by) the provisions of the Cable/Internet Agreement referred to in the Section of this Prospectus entitled "Management of the Association and Maintenance and Operation of the Condominium Property". In the event that a Unit Owner wishes to install a satellite dish or individual antenna, Unit Owners agree to be bound by and comply with the terms and provisions on any Satellite Dish and Antenna Addendum referred to as Exhibit "G" in the Cable/Internet Agreement. The foregoing is subject to the provisions of Section 8.2.13 and other applicable provisions of the Master Covenants.

For these and other restrictions upon the use of Units and Common Elements, reference should be made to all Exhibits contained in this Prospectus (particularly Sections 9 and 17 of the Declaration) the Rules and Regulations attached to the By-Laws.

I have received information on satellite dishes. If I wish to install one, I must first fill out an architectural modification form for the Board's Approval.

Signature _____

Date _____

Signature _____

Date _____



EMERALD DUNES GOLF COURSE NOTICE

Being a resident of Emerald Dunes does not give you access of any kind to the golf course. Anyone found on the golf course without the authorization of the Emerald Dunes Golf Club will be prosecuted. If you are not a member of the Emerald Dunes Golf Club, please do not enter the course without their approval.

THE VILLAS AT EMERALD DUNES WILL NOT BE HELD LIABLE FOR ANY OF YOUR ACTIONS ON THE EMERALD DUNES GOLF COURSE.

We have received the Rules and Regulations from the monument office and will abide by the rules of the association as it pertains to the Villas at Emerald Dunes.

Name: _____ Building Number: _____ Unit Number: _____

Signature: _____ Date: _____

Signature: _____ Date: _____



Vehicle Registration Form

Building Number: _____ **Unit Number:** _____

Name: _____

Phone: _____

ALL REGISTERED VEHICLES MUST HAVE THEIR DECALS DISPLAYED AT ALL TIMES AND ANY UNAUTHORIZED OR ILLEGALLY PARKED VEHICLES ARE SUBJECT TO TOW AT VEHICLE OWNERS EXPENSE.

Vehicle 1: Make: _____ Model: _____ Color: _____

Tag: _____ State: _____

(The following will be provided at orientation) Parking Space Number: _____

Decal Type: Assigned Rental Space Expire Date: _____

Vehicle 2: Make: _____ Model: _____ Color: _____

Tag: _____ State: _____

(The following will be provided at orientation) Parking Space Number: _____

Decal Type: Assigned Rental Space Expire Date: _____

Vehicle 3: Make: _____ Model: _____ Color: _____

Tag: _____ State: _____

(The following will be provided at orientation) Parking Space Number: _____

Decal Type: Assigned Rental Space Expire Date: _____

Notice to Driver: Resident must notify management if the vehicle is sold. All unauthorized vehicles which are parked on the subject property and all vehicles parked on the subject property in unauthorized places shall be towed at the sole discretion of the Manager, and at the vehicle owner's or operator's expense. Resident agrees to hold Manager harmless, defend, and indemnify the Manger for any expense or damages caused by the towing of unauthorized and or illegally parked vehicles from the Apartment community property. Any vehicles parked on sidewalks, in fire zones or in other unauthorized spaces, or inoperable vehicles or those without a current license tag shall be towed at Residents' expense.

Signature Vehicle (1): _____ **Date:** _____

Signature Vehicle (2): _____ **Date:** _____

Signature Vehicle (3): _____ **Date:** _____



Dear Property Owners & Property Management Companies,

Welcome to The Villas at Emerald Dunes Community!

RE: Information for property owners & tenants

Is this property an investment property? If so, please see the below information as it can be useful for both tenants and homeowners.

When leasing out your property all tenants have an orientation before their move-in date & all documents are received (7) before the move-in date. The following requirements for The Villas at Emerald Dunes are listed below.

Tenant information packet/ Orientation form

- a) Pet Information: See attached restrictions photo & vaccination records.
- b) Signed lease agreement.
- c) Criminal background check
- d) Copy of Driver's license

Attached is additional information for the tenant's reference.

- a) Broad Star Pamphlet-only provider for the Community
- b) Rules & Regulations
- c) Site Map
- d) Visitor call box instructions
- e) Architectural review application policy

Lease renewal & Parking

If the occupied tenant is renewing their lease, please provide the office with a copy of the renewal or lease extension. You can send the information to gcope@grsmgt.com. Tenants are responsible for obtaining a renewed parking decal. If your tenant needs to purchase an additional parking space, we offer an assigned parking space (if available) at \$50.00 monthly due on the 1st or the 15th of every month. We accept checks or money orders only. If payment is received after the due date, it is considered late and will accrue a \$10.00 late fee. All tenants must be informed of their parking spaces when signing the lease agreement. Please note our community has limited parking.

Amenity Pass

All Residents must have an amenity pass while at the fitness centers, pool & business center. Each amenity pass is \$15.00. Acceptable payment methods are checks or money orders made payable to The Villas at Emerald Dunes.

Remote/Fob

Key fob/Remotes are \$50.00 each. Fobs will give access to the vehicle gates, pedestrian gates, & gyms. Acceptable payment methods are checks or money orders made payable to The Villas at Emerald Dunes.



Assessment Payment information

Please take note of the essential information you need to know to support a smooth transition.

There are three (3) options to choose from in making your payments. Please see attached Assessment information sheets (3) pages.

Payments by mail or bill payment service:

The Villas at Emerald Dunes Condo Assn, Inc
c/o GRS Community Management, P.O. BOX 165109, Miami, FL 33116-5109

- 2) **ACH PAYMENTS:** If you were registered for automatic withdrawals with GRS, please complete the enclosed form and return it to us with a voided check. Forms received on or before the 20th of the month will be effective the following month.
- 3) **Online payments:** Owners may make payments online using a credit or echeck via the GRS website at www.grsmgt.com. On your first visit to this website, you will need to register by clicking on "Make a payment." Owners must register with your property address, within your association, so we can recognize your account. Once you have login credentials, you will be able to select from making one-time or re-occurring payment transactions. A small third-party convenience service fee will apply.

Even if you choose a different payment option, we encourage all owners to register at www.grs.cincwebaxis.com as this will provide additional access to your Association account. Choose to opt-in for emails to receive periodic Association news communications.

Your account must be at a ZERO balance to EFT to set up automatic withdrawals through GRS. If you should have any questions, please do not hesitate to contact our dedicated Resident Service team at (561) 641-8554 or by email at: Residentservices@grsmgt.com

Dryer Vents

Important Message: The Villas at Emerald Dunes dryer vents are all individual to the unit. This means it is the owners' responsibility to complete the preventative maintenance of the dryer vents. It is recommended that you have your dryer vents cleaned to prevent any issues, fires, or leaks. In some cases, dryer vent cleaning needs to be done more often. Please see attached Dryer Vents letter.

Air Conditioning Unit

The air conditioning units are all individual to the unit. This means it is the owners' responsibility to complete the preventative maintenance of the air conditioning units. It is recommended that you service your air conditioning system every six months. The air conditioning system is to be maintained to the Unit temperature, whether occupied or not, at 78° F, to minimize humidity in



the Unit. While the foregoing is intended to minimize the potential development of molds, fungi, and mildew.

Maintenance Vendor Process

All maintenance vendors coming on the property to perform work are required to check in at the office prior to entering a unit. The office address is 6442 Emerald Dunes Dr.

Vendors must supply the office with the following paperwork prior to starting work:

Contract's license and insurance certificate for work's comp and liability,
Make sure the address on the insurance certificate holder is as follows and that we are marked as Additionally insured:

The Villas at Emerald Dunes condominium Association, Inc.
6442 Emerald Dunes Dr.
West Palm Beach, FL 33411

Plumbers - If the repair requires the water to be shut off, we need a 48-hour lead time so we can post notices for the building.

Realtors

Realtors & lenders can order questionnaires or estoppel at www.grsmgt.com

Lease agreements & renewal

DECLARATION OF THE VILLAS AT EMERALD DUNES 17.8 Leases.

Renting/Leasing out your unit on a short-term basis and/or through Air BnB is prohibited per the Association documents. No lease of a unit shall be for a period of less than two (2) consecutive months and no unit may be leased more than twice in any twelve (12) month period. The community does not permit Airbnb rentals. Please be advised if the occupied tenant is renewing their lease that our office has a copy of the renewed lease that can be forwarded to Atrimble@grsmgt.com.

Pet Restrictions

DECLARATION OF THE VILLAS AT EMERALD DUNES 17.3

No Owner occupant of a Unit, including lessees and guests, shall be permitted to maintain any animals in their Unit or the Condominium Property except as permitted herein. Each Owner or occupant (regardless of the number of joint owners or occupants) of a one bedroom Unit may maintain one (1) cat or dog in his Unit, and each Owner or occupant (regardless of the number of joint owners or occupants) of a two bedroom or three bedroom Unit may maintain two (2) cats and/or dogs (i.e., 1 cat and 1 dog or 2 dogs or 2 cats). Each dog cannot weigh more than 35 pounds. Each cat cannot weigh more than 15 pounds. Caged birds and a fish tank as provided below may be maintained in a Unit provided. The foregoing is permitted provided that such pets are: (a) permitted to be so kept by applicable laws and regulations, (b) not left unattended



on balconies (except that bird cages and fish tanks will not be permitted in balconies), (c) generally, not a nuisance to residents of other Units or of neighboring buildings and (d) not a German Shepherd, Rottweiler, Doberman Pinscher or any breed or bull terrier or similar dog commonly referred to as a “pit bull” or other breed considered to be dangerous by the Board of Directors; provided that neither the Board nor the Association shall be liable for any personal injury, death or property damage resulting from a violation of the foregoing and any occupant of a Unit committing such a violation shall fully indemnify and hold harmless the Board of Directors, the Developer, each Unit Owner and the Association in such regard. Our community strives for cleanliness. All pet owners must pick up their dog’s solid waste as stated in the rules & regulations. An application must be submitted for assistance animal/emotional support animals with the Association, please request the application through our association by calling 561-684-3140.

Keys -The management office is required to have a working key to your unit for annual inspections. The unit key can be mailed or dropped off at our management office at 6442 Emerald Dunes Drive.

Include the enclosed key in a sealed envelope labeled with the property address and name.

Thank you,

The Villas at Emerald Dunes team



3900 Woodlake Blvd, Suite 309, Lake Worth, FL 33463 Tel 561.641.8554 Fax 561.641.9448

THE VILLAS OF EMERALD DUNES CONDOMINIUM ASSOCIATION, INC.

Dear Homeowner:

September 25, 2020

We are pleased to inform you effective **October 1, 2020**, GRS Community Management has been engaged by your Board of Directors to provide management and accounting services for your community. In this letter we will provide information about our company, the best ways to find important information you may need and where to direct your association payments.

GRS Community Management is a local South Florida company that has been in business for over 30 years. Our goal is to establish a long-term relationship with your association, to build stability and harmony, and to provide compliance and efficiencies to your community. We accomplish this through great people, strong processes, and proprietary technology to enhance communication with your Board of Directors and every homeowner.

We are in the process of building your community's page within the GRS website that will contain pertinent information about your community such as FAQs and important forms. You can also pay your assessments and contact our office through the community page. Live chat is also available during business hours. Please take a moment to bookmark <https://www.grsmgt.com> and look for your community web page under the "FIND MY COMMUNITY" menu selection. The page will be available in the next few weeks.

We also encourage all owners to register at www.grs.cincwebaxis.com to provide additional access to your Association account. By creating an account, you can check your balance, print a statement, and even make payments to your association all without having to make a phone call or a trip to the mailbox!

Please review Page 2 for important assessment payment options.

We look forward to working with your Community! Amy Trimble will continue to serve as the community's Property Manager and she can be contacted at the The Villas at Emerald Dunes onsite office during business hours at (561) 684-3140 or by email to ATrimble@grsmgt.com. If you need support with payments, please contact our Resident Services team at (561)641-8554 or by email at ResidentServices@grsmgt.com. For after hour emergencies, please call (561)641-8554 and follow the prompts.

Sincerely,

GRS Community Management Team



3900 Woodlake Blvd, Suite 309, Lake Worth, FL 33463 Tel 561.641.8554 Fax 561.641.9448

ASSESSMENT PAYMENT INFORMATION

Please take note of the important information you need to know to support a smooth transition. We are committed to providing you with a high level of service. We have partnered with CINC Systems to provide our payment processing systems for efficient and timely banking records for your community.

Please discard any old coupons or coupon booklets and begin using the new coupons enclosed immediately. Coupons are enclosed for the period of October, November and December 2020 assessment payments.

If you have already mailed your payment to the previous management company, it will be forwarded to GRS but there may be a delay in processing.

There are three (3) options to choose in making your payments:

1. **PAYMENTS BY MAIL OR BILL PAYMENT SERVICE:** If you are currently paying your assessment online through your banking institution or using an online bill payment service, **change the address to ensure your payment is posted accurately.**

The Villas at Emerald Dunes Condo Assn, Inc.
c/o GRS Community Management, P.O. Box 165109, Miami, FL 33116-5109

2. **ACH PAYMENTS:** If you were registered for automatic payments with the previous management company, we have requested your current ACH registrations be cancelled for 10/1/2020.

To register for automatic payments with GRS, please complete the enclosed form and return it to us with your voided check. Forms received on or before the 20th of the month will be effective the following month.

3. **Online Payments:** On or after **October 5, 2020**, owners may make payments online using a credit card or eCheck via the GRS website at www.grsmgt.com. On your first visit to this website, you will need to register by clicking on "Make A Payment". Owners must register with your property address within your association so we can recognize your account. Once you have your login credentials, you will be able to select from making one-time or re-occurring payment transactions. A small third-party convenience service fee will apply.

Even if you choose a different payment option, We encourage all owners to register at www.grs.cincwebaxis.com as this will provide additional access to your Association account. Choose to Opt in for emails to receive periodic Association news communications.



3900 Woodlake Blvd., Suite 309, Lake Worth, FL 33463
Ph: (561) 641-8554 / Fx: (561) 641-9448
www.GrsMgt.com

Name of Community/Association

ELECTRONIC FUNDS TRANSFER AUTHORIZATION

Association Account #: _____

Property Address: _____

I/We hereby authorize GRS Community Management to initiate EFT debit entries (withdrawals) from my/our checking account for credit to the below named account on the **FIFTH (5TH) day of each month/quarter** based upon the Association's budget. This authority will remain in effect until I/we notify you. I/we understand the amount of the debit may change on an annual basis according to the requirements of the Association named above. I/we acknowledge that the origination of EFT transactions to my/our account must comply with the provisions of US law.

Bank Name: _____

Bank Account Number: _____

Bank Routing Number: _____
(9-digit number found on the lower left side of your check)

First Payment Date to be debited from your account: _____

****The deadline date for new registrations or changes is the 20th of the month to be effective for the following month.

Account Owner Signature: _____

Account Owner Print Name: _____

Date Signed: _____ Phone #: _____

Email: _____

YOU MUST INCLUDE A BLANK VOIDED CHECK

Please continue to mail your remittances until you receive confirmation from GRS of the automatic draft. **Also please note that Special Assessment Payments are NOT eligible for EFT payments.**

Your account must be at a ZERO balance in order for EFT to be processed and set up for payments.

If you should have any questions, please do not hesitate to contact our dedicated Resident Services team at (561) 641-8554 or by email to: ResidentServices@grsmgt.com.



CERTIFICATE OF APPOINTMENT OF VOTING REPRESENTATIVE

To the Presidents of the Villas at Emerald Dunes
Condominium Association

THIS IS TO CERTIFY that the under signed, constituting all of the record owners of Building number _____, Unit number _____ in Condominium Association, Inc., have designated _____ name of voting (representative) As their representative to cast all votes and to express all approvals that such owners may be entitled to cast or express at all meetings of the Association and for all other purposes provided by the declaration, the articles and the bylaws of the Association.

The following examples illustrate the proper use of this certificate:

1. Unit owners for John Doe and his brother, Jim Doe. Voting Certificate required designating either John or Jim as the voting representative (not a third party).
2. Unit owned by Overseas, Inc., a corporation. Voting Certificate must be filed designating an officer or employee entitled to vote, signed by the President or Vice President of the corporation and attested by the Security or Assistant Secretary of the corporation.
3. Unit owned by John Jones. No voting certificate required.
4. Unit owned by Bill and Mary Rose, husband and wife. Voting certificate required.

This certificate is made pursuant to the declaration and the bylaws and shall revoke all prior certificates and be valid until revoked by a subsequent certificate.

DATE: _____

Owner: _____

Owner: _____

Owner: _____

NOTE: This form is **not a proxy** and should not be used as such. Please be sure to designate **one of the joint owners** of the unit, not a third person, as the voting representative.

SCHEDULE "A" TO BY-LAWS
RULES AND REFULATIONS FOR
THE VILLAS AT EMERALD DUNES CONDOMINIUM ASSOCIATION

1. The sidewalks, entrances, passages, lobbies, and hallways and like portions of the Common Elements shall not be obstructed nor used for any purpose other than for ingress and egress to and from the Condominium Property; nor shall any carts, bicycles, carriages, chairs, tables, or any other objects be stored therein, except in areas (if any) designated for such purposes.
2. The personal property of Unit Owners and occupants must be stored in their respective Units.
3. No articles other than patio-type furniture shall be placed on the balconies or terraces or other Common Elements or Limited Common Element. The use of barbecues and grills is not permitted on balconies or terraces. No lines, cloths, towels, clothing bathing suits, or swim wear, curtains, rugs, mops, or laundry of any kind, or other articles, shall be shaken, dusted, or hung from any of the windows, doors, balconies or terraces or other portions of the Condominium or Association Property or left on a balcony or terrace. Balconies or terraces may not be used as storage areas (except for any storage spaces which are part of the terrace or balcony).
4. No Unit Owner or occupant shall permit anything to fall from a window, balcony or door of the Condominium or Association Property, nor sweep or throw from the Condominium or Association Property any dirt or other substance onto or from any of the balconies or elsewhere in the buildings or upon the Common Elements.
5. No garbage, refuse, trash, or rubbish shall be deposited except as permitted by the Association. The requirements from time to time of the company or agency providing trash removal services for disposal or collection shall be complied with. All equipment for storage or disposal of such material shall be kept in a lean and sanitary condition.
6. No Unit Owner or occupant shall make or permit any disturbing noises by himself or his family, servants, employees, pets, agents, visitors, or licensees, nor permit any conduct by such person or pets that will interfere with the rights, comforts or conveniences of other Unit Owners or occupants. No Unit Owner or occupant shall play or permit to be played any musical instrument, nor operate or permit to be operated a phonograph, television, radio or sound amplifier in his Unit or Attached Garage or Detached Garage in such a manner as to disturb or annoy other residents. No Unit Owner or occupant shall conduct, nor permit to be conducted, vocal or instrumental instruction at any time which disturbs other residents.
7. Employees of the Association are not to be sent out by Unit Owners or occupants for personal errands. The Board of Directors shall be solely responsible for directing and supervising employees of the Association.

8. No repair of vehicles shall be made on the Condominium Property (except in Attached Garages and Detached Garages in accordance with the provisions of paragraph 19 hereof). Parking and Vehicle Restrictions. No boats, boat trailers, house trailers, mother homes, trucks, camping trailers, vans, motorcycles, motor scooters, go-carts, motorbikes, or other similar vehicles whether of a recreational nature or otherwise, with the exception only of four-wheel passenger automobiles, shall be placed, parked, or stored upon the Condominium except within a building and totally removed from public view. No maintenance or repair shall be done upon any such boat, trailer, or motor vehicle, including four-wheel passenger automobiles, except when in a Building and totally isolated from public view. Notwithstanding the foregoing, vehicles of repairmen, delivery men, moving vans, temporary guest or vehicles owned or leased by Unit Owner's or the Condominium Association's employees, agents or family may be parked at curbside of the Condominium for no longer than two (2) hours in a twenty-four hour (24) hour period and on the driveways and private parking areas of the Condominium for no longer than (4) hours in a twenty-four (24) hour period. Furthermore, guests of the Unit Owner, visiting for an extended period of time, may park their vehicles on the driveways and private parking areas of the Condominium for the duration of their stay. Such guests may not park at curbside except as set forth herein above. The Master Association shall have the right to authorize the towing of any vehicles which are in violation of these provisions, and/or the Traffic Regulations promulgated by the Master Association, and to collect the cost thereof from the Condominium Association, as an individual assessment. Exceptions will be granted for installation trucks, repair trucks and catering trucks while workers ply their trade. See Section 8.3.9 and 8.4.4 of the Master Covenants for additional restrictions.
9. No sign, advertisement, notice or other graphics or lettering shall be exhibited, displayed, inscribed, painted, or affixed in, on or upon any part of the Condominium or Association Property, except signs used or approved by the Developer (for as long as the Developer owns any portion of the Condominium Property, and thereafter by the Board). Subject to the provisions of Sections 9 and 17 of the Declaration of condominium, no awning, canopy, shutter or other projection shall be attached to or placed upon the outside walls of the buildings or on the Common Elements, without the prior written consent of the Board of Directors of the Association.
10. No flammable, combustible or explosive fluids, chemicals or substances shall be kept in any Unit or on the common Elements except such as are normally used for normal household purposes.
11. A Unit Owner or occupant who plans to be absent during the hurricane season must prepare his Unit prior to his departure by designating a responsible firm or individual to care for his Unit should a hurricane threaten the Unit or should the Unit suffer hurricane damage and furnishing the Association with the name(s) of such firm or individual. Such firm or individual shall be subject to the approval of the Association.
12. A Unit Owner or occupant shall not cause anything to be fixed or attached to, hung, displayed, or placed on the exterior walls, doors, balconies, or windows of the buildings. Notwithstanding the foregoing any Unit Owner may respectfully display one (11) portable, removable American flag,

and on Armed Forces Day, Memorial Day, Flag Day, Independence Day, and Veterans Day any Unit owner may respectfully display portable, removable official flags not larger than four and one-half feet by six feet (4'6" x 6') that represent the United States Army, Navy, Air Force, Marine Corps, or Coast Guard. Curtains and drapes (or linings thereof) which face the exterior windows or glass doors of Units shall be subject to disapproval by the Board, in which case they shall be removed and replaced with acceptable items.

13. No oil drilling, oil development operations, oil refining, quarrying, or mining operations of any kind shall be permitted on, upon or in the Condominium or Association Property, nor shall oil wells, tanks, tunnels, mineral excavations, or shafts be permitted upon or in the condominium or Association Property. No derrick or other structure designed for use in boring for oil, natural gas or minerals shall be erected, maintained, or permitted upon any portion of the Condominium or Association Property.
14. No window air-conditioning units may be installed by Unit Owners or occupants. No Unit shall have any aluminum foil placed in any window or glass door or any reflective or tinted substance placed on any glass, unless approved, in advance by the Board of Directors in writing. No unsightly materials may be placed on any window or glass door or be visible through such window or glass doors.
15. Children will be the direct responsibility of their parents or legal guardians, including full supervision of them while within the Condominium Property and including full compliance by them with these Rules and Regulations and all other rules and regulations of the Association. Loud noises will not be tolerated. All children under twelve (12) years of age must be accompanied by a responsible adult when entering and/or utilizing the recreational facilities.
16. Dogs, cats, birds, and fish shall neither be kept nor maintained in or about the Condominium Property except in accordance with the following, in addition to the applicable terms of the Declaration:
 - a. Dogs and cats shall not be permitted outside of their owner's Unit unless attended by an adult and on a leash not more than six (6) feet long. Said dogs and cats shall only be walked or taken upon those portions of the Common Elements designated by the Association from time to time for such purposes.
 - b. Fish or caged domestic (household-type) birds may be kept in the Units, subject to the provisions of the Declaration.
 - c. Unit owners shall pick up all solid waste from their pets and dispose of same appropriately.

No Owner occupant of a Unit, including lessees and guests, shall be permitted to maintain any animals in their Unit or the condominium Property except as permitted herein. Each Owner or occupant (regardless of the number of joint owners or occupants) of a one-bedroom Unit may

maintain one (1) cat or dog in his Unit, and each Owner or occupant (regardless of the number of joint owners or occupants) of a two bedroom or three bedroom Unit may maintain two (2) cats and/or dogs (i.e., 1 cat and 1 dog or 1 dog or 2 cats.) Each dog cannot weigh more than 35 pounds. Each cat cannot weigh more than 15 pounds. Caged birds and a fish tank as provided below may be maintained in a Unit. The foregoing is permitted provided that such pets are: (a) permitted to be so kept by applicable laws and regulations, (b) not left unattended on balconies (except that bird cages and fish tanks will not be permitted in balconies). (c) generally, not a nuisance to residents of other Units or of neighboring buildings and (d) not a German Shepherd, Rottweiler, Doberman Pinscher or any breed or bull terrier or similar dog commonly referred to as a "pit bull" or other breed considered to be dangerous by the Board of Directors; provided that neither the Board nor the Association shall be liable for any personal injury, death or property damage resulting from a violation of the foregoing and any occupant of a Unit committing such a violation shall fully indemnify and hold harmless the Board of Directors, the Developer, each Unit Owner and the Association in such regard. Unless otherwise approved by the Association a Unit Owner or his tenant shall be limited to one (1) fish tank not to exceed 30 gallons.

17. Every applicable Owner and occupant shall comply with these Rules and Regulations as set forth herein, any and all rules and regulations which from time to time may be adopted, and the provisions of the Declaration, By-Laws and Articles of Incorporation of the Association and the provisions of the master Association Documents, as amended from time to time. Failure of an Owner or occupant to so comply shall be grounds for action which may include, without limitation, an action to recover sums due for damages, injunctive relief, or any combination thereof. In addition to all other remedies, in the sole discretion of the Board of Directors of the Association, a fine or fines may be imposed upon an Owner for failure of an Owner, his family, guests, invitees, Lessees, or employees, to comply with any covenant, restriction, rule or regulation herein or in the Declaration, Articles of Incorporation or By-Laws, or Master Association Documents provided the following procedures are adhered to:

- a. **Notic:** The party against whom the fine is sought to be levied shall be afforded an opportunity for hearing after reasonable notice of not less than fourteen (14) days and said notice shall include: (i) a statement of the date, time and place of the hearing; (ii) a statement of the provisions of the declaration, association by-laws, or association rules which have allegedly been violated; and (iii) a short and plain statement of the matters asserted by the association.
- b. **Hearing:** The non-compliance shall be presented to a committee of other Unit Owners, who shall hear reasons why penalties should not be imposed. The party against whom the fine may be levied shall have an opportunity to respond, to present evidence, and to provide written and oral argument on all issues involved and shall have an opportunity at the hearing to review, challenge, and respond to any material considered by the committee. A written decision of the committee shall be submitted to the Owner or occupant by not later than twenty-one (21) days after the meeting.
- c. **Fines:** The Board of Directors may impose fines against the applicable Unit up to the maximum amount permitted by law from time to time.
- d. **Violations:** Each separate incident which is grounds for a fine shall be the basis of one separate fine. In the case of continuing violations, each continuation of same after a notice thereof is given shall be deemed a separate incident.

- e. Payment of Fines: Fines shall be paid not later than thirty (30) days after notice of the imposition thereof.
 - f. Application of Fines: All monies received from fines shall be allocated as directed by the Board of Directors.
 - g. Non-exclusive Remedy: These fines shall not be construed to be exclusive and shall exist in addition to all other rights and remedies to which the Association may be otherwise legally entitled; however, any penalty paid by the offending Owner or occupant shall be deducted from or offset against any damages which the Association may otherwise be entitled to recover by law from such Owner or occupant.
18. These rules and regulations shall be cumulative with the covenants, conditions and restrictions set forth in the Declaration of Condominium, provided that the provisions of same shall control over these rules and regulations in the event of a conflict or a doubt as to whether a specific practice or activity is or is not permitted. Notwithstanding the foregoing, in the event of any conflict between the provisions of these Rules and Regulations and other Condominium Documents with the terms and provisions of the Master Association Documents, then in such event the terms and provisions of the Master Association Documents shall prevail and control. Further, anything to the contrary notwithstanding, these rules and regulations shall not apply to the Developer, nor its agents or employees and contractors, nor the Units owned by the Developer, except:
- a. Requirements that leases or lessees be approved by the Association (if applicable); and
 - b. Restrictions on the presence of pets; and
 - c. Restrictions on occupancy of Units based upon age (if any); and
 - d. Restrictions on the type of vehicles allowed to park on Condominium Property; however, the Developer or its designees shall be exempt from any such parking restrictions if the vehicle is engaged in any activity relating to construction, maintenance, or marketing of Units, subject to the provisions of the Master Covenants.
- All of these rules and regulations shall apply to all other Owners and occupants even if not specifically so stated in portions hereof. The Board of Directors shall be permitted (but not required) to grant relief to one or more Unit Owners from specific rules and regulations upon written request therefore and good cause shown in the sole opinion of the Board.
19. No Unit Owner or its tenants or their respective families, guests, agents, employees, invitees, licensees or visitors shall perform, in any Attached Garage or Detached Garage assigned to a Unit as a Limited Common Element between the hours of 9 PM and 9 AM of every day, any repair, maintenance or other work concerning their vehicle stored in the Attached Garage or Detached Garage or otherwise engage or undertake any activity which would constitute a nuisance or in any way disturb or annoy other residents ("Garage Activities"). Garage Activities which are not undertaken in a manner which constitute a nuisance or in any way disturb or annoy the residents may be undertaken solely in the parking space located inside the Attached Garage or Detached Garage (but not on the parking space which is located directly in front of the Attached Garage) between the hours of 9 AM and 9PM, Monday through Sunday.
20. Parking is prohibited in front of Detached Garages.

21. LEASES: Owners must submit a copy of the tenant's background check along with the lease, seven (7) days prior to move-in. Tenants will not be allowed to move in until all documents are received by Management.

22. LEASES: All lessee and lessor will have to sign an addendum to the lease, to establish payment by lessee to the Association if Lessor defaults in payment of Maintenance fees.

The Villas at Emerald Dunes
6442 Emerald Dunes Drive, West Palm Beach, FL 33411
ARCHITECTURAL REVIEW APPLICATION

This is a request form to be completed and submitted to the Board of Directors BEFORE any work commences and requires Board approval for all Common Ground requests and Interior requests. PROJECT MUST BEGIN WITHIN NINETY (90) DAYS AND BE COMPLETED WITHIN ONE YEAR FROM THIS REQUEST APPROVAL DATE. Complete this form in its entirety and return to the Property Manager of The Villas at Emerald Dunes.

Owner's Name: _____

Building: _____ Unit #: _____

Phone (Home) _____ (Work) _____

DESCRIBE THE CHANGE/ADDITION/INSTALLATION: (i.e., Flooring, Fixtures, Paint, etc.)

SPECIFICATIONS: (Attach a copy of the contractor's plans/owners and a suitable drawing and/or picture. Also include a sample of materials to be used for flooring, (including floor inlay. additionally, a clear copy of the contractor's liability Insurance certificate & license #.

Contractor: _____

Phone #/ Email: _____

License #: _____

Liability Insurance _____

DIMENSIONS: _____

MATERIAL(S): _____

COLOR(S): _____

Resident signature: _____ **Date:** _____

PLEASE NOTE:

No project may commence prior to unit owner receiving written approval by Condominium Association. Contractors may only work during the hours of 9:00 am to 4:00 pm Monday through Friday. All contractors, contractor vehicles, etc. must be off the premises by 5:00 pm Monday through Friday. No work is permitted Saturday and Sunday. Before commencing work, please inform the office at least 48 hours ahead of time along with an expected completion time as well so other residents may be informed of possible noise disturbances the throughout project time.

INSTRUCTIONS: Complete all pages of this form and give to the Property Manger along with all applicable attachments. The Property Manager will then forward, to the Condominium Board will then approve, conditional approval, reject or request further information. A copy of the approval will then be emailed or mailed to the Owner and modifications, alterations or improvements may begin.

THIS SECTION TO BE COMPLETED BY THE BOARD OF DIRECTORS

Request Received: _____ Date Approved: _____ Date Denied: _____

Comments:

For the Board of Directors: Signature: _____

Print Name _____

Title: _____



All contractors must sign in with the Management Office at 6442 Emerald Dunes Drive before any inspections or repairs are started on the property.

All flooring installation, remodeling, plumbing repairs and or new air conditioner installations need to be reported to the management office. There is a very specific process that needs to be followed before the work is started in your unit. Depending on the work that you will be doing inside of your unit, you may be required to submit a fully completed Architectural Review Application along with specs of the work you are doing. It is highly recommended that the first step taken is to call the management's office and inquire so you are not in violation.

Air Conditioner Unit Replacement. Prior to work starting we need the following:

Owners are required to submit to the management office a copy of the hired contractor's business license and insurance certificate for workers comp and liability.

Make sure that the Association is listed as **ADDITIONALLY INSURED AND AS THE CERTIFICATE HOLDER** on the insurance certificate.

The Villas at Emerald Dunes condominium Association, Inc.
6442 Emerald Dunes Dr.
West Palm Beach, FL 33411

The insurance certificate and license can be sent to directly to the office at gcope@grsmgt.com and/or atrimble@grsmgt.com.

If the Air Handler is being replaced inside of the unit, the owner is required to contact the Association's fire life and safety vendor (Please call the Management's office at 561-684-3140 to obtain the current vendors phone number) to request a scheduled date for them to come out and drain the fire sprinkler system for the building for the duration of the installation. Reason being, there is a sprinkler head in the AC closet of each unit that will be activated when the tech welding the air handler together. The day of the installation, the contractor must check in at the office before heading to the unit.

Same process for plumbing repairs inside of your unit. If the repair requires the water to be turned off for the entire building, you need to provide the management office with at least 48 hours' notice so we can inform all residents in the building so everyone can plan accordingly.

Any kind of work that will be done by hired contractors is required to be done Monday – Friday during the morning hours only in case maintenance assistance is needed though out the process.

Requesting Access with a Visitor Call

- Navigate to Resident Directory using Navigation keys.
- Scroll through the alphabet to the first letter of the last name.
- Press Enter.
- Scroll through name list to desired entry.
- Press Enter to call.
- If the visitor already knows the resident's directory number, they can enter the directory number to call the resident.
- The system dials the resident's telephone number to establish 2-way communications.

NOTE: The resident's telephone number will never be displayed to the visitor.

- If the resident is using the telephone at the same time a visitor calls, the display will indicate to the visitor that the line is busy.
- The resident answers the call and converses with the visitor to determine if access will be granted.
- The resident can use their telephone's keypad to grant access activating Relay Channel "A" by pressing **9**. After access is granted, the system will disconnect the visitor and resident call.
- The resident can disconnect the visitor without granting access by pressing ***** or by hanging up.

NOTE: The telephone keys that the resident presses can be customized for the installation.

- The length of time the visitor is allowed to talk can be programmed from 30-300 seconds.

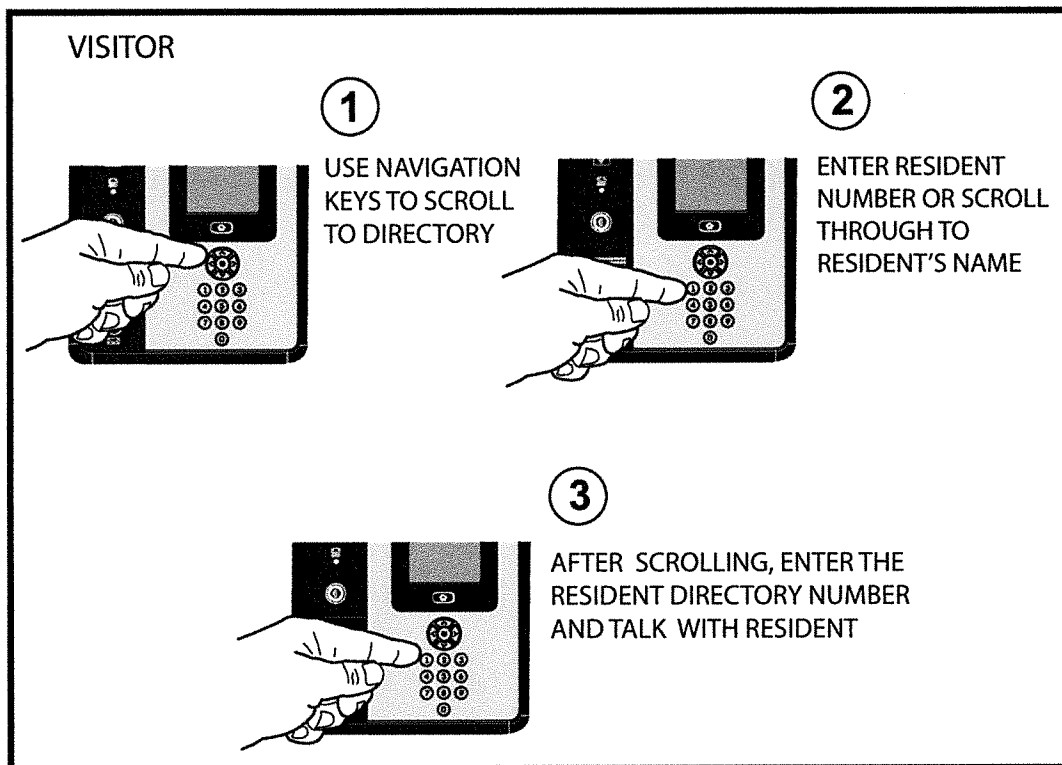

Test and Maintenance Operations

Prior to installation, ensure that all inside wiring is secure. Each unit should be checked annually for any loose wire connections.

Impaired Operation

Units are designed to operate under adverse environmental conditions. Under normal circumstances, they will function properly regardless of outside conditions. However, units do not have secondary power sources and cannot function without direct continuous power. If a unit is damaged by natural causes or deliberate vandalism, it may not function properly depending on the level of damage.

DRYER VENTS

VERY IMPORTANT MESSAGE

At The Villas At Emerald Dunes the dryer vents are all individual to the unit. This means, it is owner's responsibility to complete the preventative maintenance to the dryer vents. It is recommended that you have your dryer vents cleaned to prevent any issues, fires, or leaks. In some cases, dryer vent cleaning needs to be done more often. There are different signs to watch for.

Warning Signs to Watch for

- Increased drying time No, this does not mean you dryer is wearing o
- Clothes very hot to the touch at the end of the cycle
- Outdoor flapper on vent hood does not open when dryer is running
- Little or no airflow in the vent

The many Benefits of Dryer Vent Cleaning:

- Dryer vent cleaning eliminates home and health threats
- **Dryer vent cleaning prevents dryer fires**
- Dryer vent cleaning increases efficiency; reduces energy bills
- Dryer vent cleaning extends the life of your clothes dryer
- Dryer vent cleaning prevents premature break-down resulting in expensive repair bills
- Dryer vent cleaning improves air quality in your home, preventing mold and mildew damage and carbon monoxide poisoning.
- Dryer vent cleaning helps preserve clothing with faster drying time

Even the very best, state of the art dryer vent system requires regular cleaning to remove lint build-up and promote maximum air flow. If a dryer vent is not properly cleaned out it can cause the line to become clogged and can produce condensation to build up in the dryer line and then leak into the lower levels. It is highly recommended that you have a professional perform a dryer vent inspection. Please remember to complete this maintenance as this will prevent any future issues with your dryer, as well as prevent any fires.

We appreciate your attention regarding this matter.

The Board of Directors

The Villas At Emerald Dunes Condominium Association, Inc.

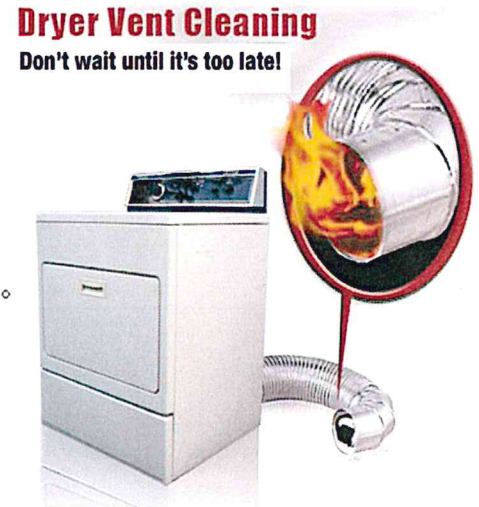



The Villas AT EMERALD DUNES

Golf Course Club House

FAIRWAY 9

FAIRWAY 1

VISTA PARKWAY

EMERALD DUNES DRIVE

PHASE I

PHASE II

6482

6442

6466

6426

6400

6510

6450

6410

6556

6492

6458

FAIRWAY 2

OKEECHOBEE BLVD.

FLORIDA BUILDING CODE.





The Villas
AT EMERALD DUNES

SECURITY 561-507-4307
MEDICAL, FIRE, LAW ENFORCEMENT 911
MANAGEMENT OFFICE 561-684-3140



AMY TRIMBLE
COMMUNITY ASSOCIATION MANAGER
6442 Emerald Dunes Drive · West Palm beach, FL 33411
Office 561-684-3140 · Fax 561-684-3690
atrimble@grsmgt.com · www.grsmgt.com



GLEND A COPE
ADMINISTRATIVE ASSISTANT
6442 Emerald Dunes Drive · West Palm Beach, FL 33411
Office 561-684-3140 · Fax 561-684-3690
gcope@grsmgt.com · www.grsmgt.com

WALLY PRIME DIGITAL / HD CABLE

LIGHTNING INTERNET

200+ DIGITAL CHANNELS
with HD CHANNELS



UP TO 500 MBPS
INTERNET

\$84.99*
/month
with bundled discount

Wally Prime Digital/HD Cable 200+ Basic Digital channels with HD & 1 Wally Receiver

\$25*/mo

Local Channels	166 CMT	205 FOX News	192 ID	170 Nickelodeon	122 Syfy
9393 3ABN	208 CNBC	180 Freeform	259 INSP	171 Nickelodeon W	260 TBN
118 A&E	200 CNN	103 Free Preview Info	227 Jewelry TV	178 Nick Toons	139 TBS
886 Alma vision	107 Comedy Central	9415 Free Speech TV	108 Lifetime	189 OWN	400 Tennis Channel
195 American Heroes	113 Cooking Channel	119 FYI	109 Lifetime Movies	127 Oxygen	232 The Cowboy channel
131 AMC	221 CRAFT	229 Gem Shopping Network	9410 Link TV	241 Paramount Network	183 TLC
184 Animal Planet	210 C-SPAN	401 Golf Channel	254 LOGO	071 QVC	138 TNT
167 AXS TV	211 C-SPAN2	116 Gameshow Network	152 MLB Network	255 QVC2	196 Travel Channel
823 Baby First	263 Daystar	130 HD Net Movies	246 Motor Trend	299 Reelz Channel	242 truTV
124 BET	9645 Deal	185 Hallmark Channel	209 MSNBC	9644 Renew	106 TV Land
203 Bloomberg TV	194 Destination America	187 Hallmark Movies	160 MTV	231 RFD-TV	105 USA Network
129 Bravo	182 Discovery Channel	202 Headline News	161 MTV2	280 RT America	162 VH1
9403 BYU TV	114 E! Entertainment	120 History Channel	163 MTV Classic	225 Sale	121 Viceland
176 Cartoon Network	9411 Enlace	880 HITN	369 MTV Live	193 Science Channel	881 V-ME
177 Cartoon Network W	224 EPIC	112 HGTV	286 NASA	257 Shahid VIP	214 Weather Channel
158 CBS Sports Net	261 Eternal World	074 HSN	186 National Geo	134 ShopHQ	128 WE
279 CGTN News	9642 FETV	268 Impact Network	156 NBA TV	276 Smart	228 YouTV
884 CGTN Espanol	110 Food Network	230 In Country Network	154 NFL Network	257 Sonlife Broadcasting	70+ SiriusXM Channels
267 Christian TV	206 FOX Business News	133 Independent Film	157 NHL Network	395 Sportsman Channel	30+ DishCD Music Channels

ADDITIONAL CABLE PACKAGES All options below require America's Top 120 or above

America's Top 120 190+ Digital channels

\$82.99*/mo

9393 3ABN	107 Comedy Central	9642 FETV	074 HSN	170 Nickelodeon E	139 TBS
118 A&E	289 Comet	243 FM	268 Impact Network	171 Nickelodeon W	232 The Cowboy Channel
131 AMC	253 Cozi TV	110 Food Network	230 In Country Network	241 Paramount Network	258 The Hillsong Channel
219 America's Voice	166 CMT	206 FOX Business News	133 Independent Film	117 Pop	138 TNT
184 Animal Planet	221 CRAFT	205 FOX News Channel	134 INSP	393 Pursuit Channel	399 TVG
167 AXS TV	210 C-SPAN	150 FOX Sports 1	192 ID	284 Recipe Channel	398 TVG2
218 Binge TV	211 C-SPAN2	180 Freeform	227 Jewelry TV	071 QVC	106 TV Land
360 Black News	263 Daystar	103 Free Preview Info	240 Justice Central	255 QVC2	105 USA Network
359 Bounce	278 DEAL	9415 Free Speech TV	108 Lifetime	299 Reelz Channel	104 Value TV
370 Circle	182 Discovery Channel	164 FUSE	9410 Link TV	9644 Renew	881 V-ME
129 Bravo	172 Disney Channel E	136 FX	250 ION	280 RT America	162 VH1
245 BUZZR	173 Disney Channel W	125 FXX	247 ME TV	225 Sale	214 Weather Channel
084 BuyTV	9411 Enlace	248 GAC Living	246 Motor Trend	257 Sonlife Broadcasting	215 Weather Nation
9403 BYU TV	114 E! Entertainment	229 Gem Shopping Network	209 MSNBC	659 Shahid VIP	239 WGN America
176 Cartoon Network E	224 Epic	373 Get TV	160 MTV	276 Smart	128 WE
177 Cartoon Network W	261 EWTN	217 GRIT	161 MTV2	291 Start TV	228 You TV
279 CGTN News	140 ESPN	202 Headline News	369 MTV Live	122 Syfy	70+ SiriusXM Channels
884 CGTN Espanol	143 ESPN2	293 Heroes and Icons	286 NASA	183 TLC	30+ DishCD Music Channels
267 Christian TV	142 ESPNnews	120 History Channel	197 National Geographic	196 Travel Channel	
208 CNBC	141 ESPNU	880 HITN	216 Newsmax	242 truTV	
200 CNN	387 Family Movie Classics	112 HGTV	283 Newsy	260 TBN	

America's Top 200 240+ Digital channels Includes channels in AT120

\$97.99*/mo

402 ACC Network	174 Disney XD	185 Hallmark Channel	396 Outdoor Channel	157 NHL Network	828 Univision West
135 BBC America	111 DIY	187 Hallmark Movies	127 Oxygen	260 TBN	188 UP
124 BET	852 Estrella	250 ION	231 RFD-TV	139 TBS	121 Vice
410 Big Ten Network	149 FOX Sports 2	109 Lifetime Movies	193 Science Channel	400 Tennis	396 World Fishing
175 Boomerang	119 FYI	407 Longhorn Network	408 SEC	181 Teen Nick	858 Zona Futbol
158 CBS Sports Network	833 Galavision	152 MLB Network	126 Sundance TV	856 TUDN	70+ SiriusXM Channels
113 Cooking Channel	401 Golf Channel	169 Nick Jr.	190 Nat Geo WILD	132 Turner Classic Movies	30+ DishCD Music Channels
179 Discovery Family	116 GSN	389 Olympic Channel	156 NBA TV	830 UniMÁS E, W	
168 Disney Jr.	186 Hallmark Drama	189 OWN	154 NFL Network	827 Univision East	

America's Top 250 290+ Digital channels Includes channels in AT200

\$107.99*/mo

195 American Heroes	254 LOGO	346 StarzEncore Classic
392 beIN Sports	377 MoviePlex	348 StarzEncore Español
873 beIN en Español	163 MTV Classic	347 StarzEncore Family
251 BET her	178 Nick Toons	344 StarzEncore Suspense
203 Bloomberg TV	367 Smithsonian	342 StarzEncore Westerns
194 Destination America	395 Sportsman Channel	329 The Movie Channel W
292 Epix Drive-In	340 StarzEncore E	330 The Movie Channel Xtra W
384 FOX Movie Channel	341 StarzEncore W	838 Universo
244 Fusion	343 StarzEncore Action	
165 GAC Family	345 StarzEncore Black	

Additional channels

Requires America's Top 200 or 250

Multi-Sports Pack

\$13*/mo

NFL RedZone, NFL Network, Pac-12 Networks, Big Ten Network, NBA TV, NHL Network, MLB Network, MLB Strike Zone, FXX, Fox Sports 2, Universal Sports Network and over 20 Regional Sports Networks.

SHOWTIME: 9 Channels \$15*/mo | STARZENCORE: 8 Channels \$10*/mo

Customer Service: 561-472-5006 or online at BroadStar.com/EmeraldDunes



*Channels available in HD are printed in bold. Local blackout restrictions may apply. Programming and prices subject to change and do not include taxes, equipment, and applicable fees such as the Broadcast TV Fee. Up to 500 Mbps Internet speeds are available via hard-wired Ethernet connections and on compatible devices. v.1.11.22 DS

Welcome to BroadStar

GET LIGHTNING INTERNET SPEEDS UP TO 500 Mbps!



Basic Cable TV:
80+ BASIC channels
RECEIVER NOT REQUIRED

**INCLUDED
IN YOUR
COMMUNITY**

3 Gate Channel	28.1 BET	56.1 Weather channel
2.1 Guide channel	29.1 Oxygen	57.1 TLC
3.1 ABC WPBF	30.1 WE	58.1 Animal Planet
4.1 NBC WPTV	31.1 BRAVO	59.1 Hallmark
5.1 CBS WPEC	32.1 HDNET Movies	60.1 Hallmark Movies
6.1 FOX WFLX	33.1 AMC	61.1 OWN
7.1 CW WTVX	34.1 IFC	62.1 ID
8.1 PBS WXEL	35.1 QVC	63.1 Science channel
9.1 ION WPXP	36.1 QVC Plus	64.1 Travel channel
10.1 Court TV WHDT	37.1 TNT	65.1 Nat Geo
11.1 USA	38.1 TBS	66.1 CNN
12.1 TruTV	39.1 Paramount Network	67.1 Headline News
13.1 Comedy Central	40.1 Fusion	68.1 Bloomberg TV
14.1 TV Land	41.1 Dish Studio	69.1 FOX News
15.1 Lifetime	42.1 Azteca America	70.1 FOX Business
16.1 Lifetime Movies	43.1 CBS Sports Net	71.1 CNBC
17.1 FOOD Network	45.1 MTV	72.1 MSNBC
18.1 DIY	46.1 MTV2	73.1 CSPAN
19.1 HGTV	47.1 VH1	74.1 CSPAN2
20.1 Cooking channel	48.1 MTV Classic	75.1 Destination America
21.1 E! Entertainment	49.1 CMT	76.1 The Cowboy channel
22.1 Gameshow Network	50.1 AXS	77.1 LOGO
23.1 A&E	51.1 Nickelodeon	78.1 REELZ
24.1 FYI	52.1 Nickelodeon W	79.1 RFD-TV
25.1 History channel	53.1 Cartoon Network	80.1 Cartoon Network W
26.1 Viceland	54.1 Discovery channel	
27.1 SYFY	55.1 Freeform	

Lightning Internet
UP TO 500 MBPS

\$59⁹⁹*
/mo
with Bundled
Discount

BROADSTAR



BroadStar.com/EmeraldDunes



Customer Service: 561-472-5006

\$25*/mo

WALLY PRIME DIGITAL/HD CABLE

200+ Digital channels with HD & 1 HD receiver

Local Channels		
25 ABC (WPBF)	9411 Enlace	154 NFL Network
17 Azteca (WWHB)	224 EPIC	157 NHL Network
12 CBS (WPEC)	261 Eternal World	170 Nickelodeon
34 CW (WTVX)	9642 FETV	171 Nickelodeon W
29 FOX (WFLX)	110 Food Network	178 Nick Toons
67 ION (WPXP)	206 FOX Business News	189 OWN
5 NBC (WPTV)	205 FOX News	127 Oxygen
42 PBS (WXEL)	180 Freeform	241 Paramount
21 TBN (WTCE)	103 Free Preview Info	071 QVC
Additional Channels	9415 Free Speech TV	255 QVC2
9393 3ABN	119 FYI	299 Reelz Channel
118 A&E	229 Gem Shopping Network	9644 Renew
886 Alma vision	401 Golf Channel	231 RFD-TV
195 American Heroes	116 GSN	280 RT America
131 AMC	130 HD Net Movies	225 Sale
184 Animal Planet	185 Hallmark Channel	193 Science Channel
167 AXS TV	187 Hallmark Movies	257 Shahid VIP
823 Baby First	202 Headline News	134 ShopHQ
124 BET	120 History Channel	276 Smart
203 Bloomberg TV	880 HITN	257 Sonlife Broadcasting
129 Bravo	112 HGTV	395 Sportsman
9403 BYU TV	074 HSN	122 Syfy
176 Cartoon Network	268 Impact Network	260 TBN
177 Cartoon Network W	230 In Country Network	139 TBS
158 CBS Sports Net	133 IFC	400 Tennis Channel
279 CGTN News	192 ID	232 The Cowboy channel
884 CGTN Espanol	259 INSP	183 TLC
267 Christian TV	227 Jewelry TV	138 TNT
166 CMT	108 Lifetime	196 Travel Channel
208 CNBC	109 Lifetime Movies	242 truTV
200 CNN	9410 Link TV	106 TV Land
107 Comedy Central	254 LOGO	105 USA Network
113 Cooking Channel	152 MLB Network	162 VH1
221 CRAFT	246 Motor Trend	121 Viceland
210 C-SPAN	209 MSNBC	881 V-ME
211 C-SPAN2	160 MTV	214 Weather Channel
263 Daystar	161 MTV2	128 WE
9645 Deal	163 MTV Classic	228 YouTV
194 Destination America	369 MTV Live	70+ SiriusXM Channels
182 Discovery Channel	286 NASA	30+ DishCD Music Channels
114 E! Entertainment	186 Nat Geo	
	156 NBA TV	

561-472-5006 | BroadStar.com/EmeraldDunes

*Channels available in HD are printed in bold. Local blackout restrictions may apply. Prices subject to change and do not include taxes, equipment, and applicable fees such as the Broadcast TV Fee and the Regional Sports Network Fee. Up to 500 Mbps Internet speeds are available via hard-wired Ethernet connections and on compatible devices. Programming subject to change without notice. v.1.19.22 DS